

Torque Wrench Care

- After using the wrench, unlock and turn the adjuster to the lowest setting for storage. Take care not to turn the adjuster lower than the minimum torque setting or the mechanism may be damaged.
- Take care of the torque wrench and keep it clean; return all components to box when not in use.
- Do not store in areas of high temperatures or humidity.
- Never use the torque wrench to tighten a fastener to a higher torque than the maximum reading on the scale.



Safety First. Be Protected.

LASER®

TPMS Torque Set

Instructions



Guarantee

If this product fails through faulty materials or workmanship, contact our service department direct on: **+44 (0) 1926 818186**. Normal wear and tear are excluded as are consumable items and abuse.

TOOL CONNECTION
The Complete Connection

Distributed by The Tool Connection Ltd

Kineton Road, Southam, Warwickshire CV47 0DR
T +44 (0) 1926 815000 F +44 (0) 1926 815888
info@toolconnection.co.uk www.toolconnection.co.uk



Comprehensive Tyre Pressure Monitoring System (TPMS) set that contains tools required to correctly mount the TPMS sensor to the wheel rim. Includes two ¼"D torque wrenches to tighten TPMS sensor valve nuts to specific torque settings. The kit includes both T10 and T20 bits to be used when the tyre valve is detachable from sensor.

BUTTS OF BAWTRY
ESTABLISHED SINCE 1971

Butts of Bawtry

Station Yard Bawtry Doncaster South Yorks DN10 6QD UK
Tel: 0044 (0)1302 710868 Fax: 0044 (0)1302 719481
Web: www.buttsofbawtry.com Email: info@buttsobawtry.com

Contents

The set includes:

- Torque Wrench 2 - 10Nm.
- Torque Wrench 0.4 - 2Nm.
- ¼"D T-handle.
- 100mm extension bar.
- 12mm deep socket.
- 11mm deep socket.
- ¼"D valve stem tool.
- ¼"D T10 socket | bit.
- ¼"D T20 socket | bit.
- Grommet | spacer ring tool.

- During operation, when the preset torque is reached, the torque wrench will 'click' and disengage to indicate that the selected torque tensioning has been reached.

Set in foam for security and supplied in steel box.

Set Components:

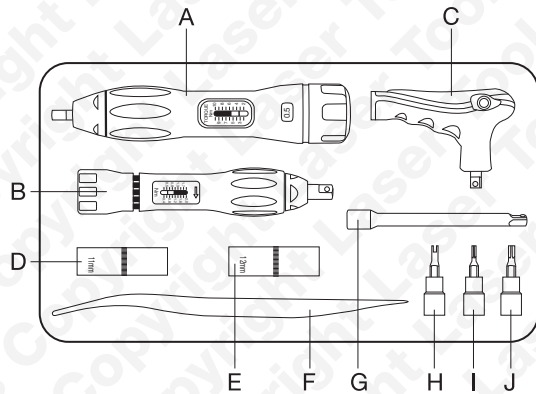

Code	Description
A	Torque wrench (2 - 10Nm)
B	Torque wrench (0.4 - 2Nm)
C	¼"D T-handle
D	11mm deep socket
E	12mm deep socket
F	Grommet spacer ring tool
G	100mm extension bar
H	¼"D valve stem tool
I	¼"D T10 socket bit
J	¼"D T20 socket bit

Sensor Components

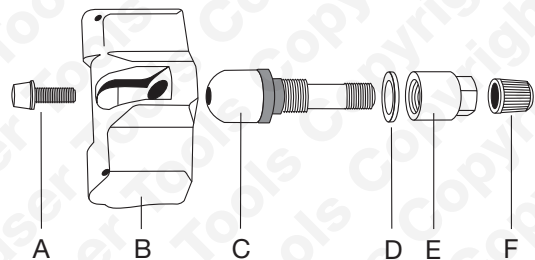

Code	Description
A	Mounting screw
B	TPMS sensor
C	Valve (c/w seal grommet)
D	Spacer ring
E	Securing nut
F	Valve cap

Operation

Always refer to the manufacturer's instructions | documentation before attempting to remove or refit a TPMS sensor.

Refer to diagram 'Sensor Components'. Some sensors have a detachable valve body; this is usually secured with a self-locking mounting screw (A) — the ¼"D T10 and T20 socket | bits are supplied for this screw.

Torque Wrench Components:

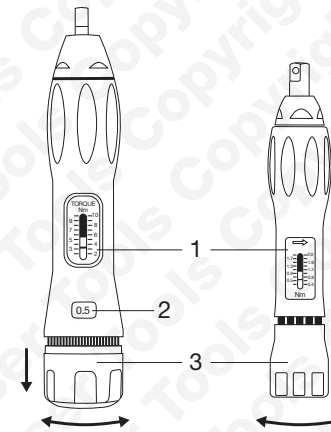

Code	Description
1	Indicator (Nm)
2	Indicator (tenths)
3	Lock/Adjuster

Refer to diagram 'Torque Wrench Components'. The torque wrench is used when refitting or fitting a new sensor to the wheel rim. Refer to manufacturer's documentation for the correct torque figure for the valve securing nut (E in 'Sensor Components' diagram).

To set the torque wrench:

1. Pull the lock | adjuster (3) down to free the adjuster.
2. Turn adjuster clockwise to increase (anticlockwise to decrease) the tension setting.
3. Set the Nm indicator (1) and then (on the 2 - 10Nm torque wrench) fine tune the setting by referring to the tenths indicator (2) - the correct setting is when the figure (e.g., 0.5) is displayed in the centre of the indicator window.
4. Push lock | adjuster (3) up and fully home to lock the setting.
5. If using the 2 - 10Nm torque wrench, attach ¼"D T-handle and choose the correct deep socket (11mm or 12mm) for the valve securing nut.
6. If using the 0.4 - 2Nm torque wrench, choose the correct deep socket (11mm or 12mm) for the valve securing nut, there is no need for the T-handle at these lower torque settings.

Precautions

- Hold the torque wrench carefully and keep it straight so that sideways pressure is not being applied to the valve body.
- Hold the sensor unit carefully and keep it straight so that sideways pressure is not being applied as the valve securing nut is tightened.
- Tighten the valve securing nut in a slow and controlled manner and stop applying pressure immediately the torque wrench clicks. Tightening too quickly will result in an inaccurate final torque figure.